

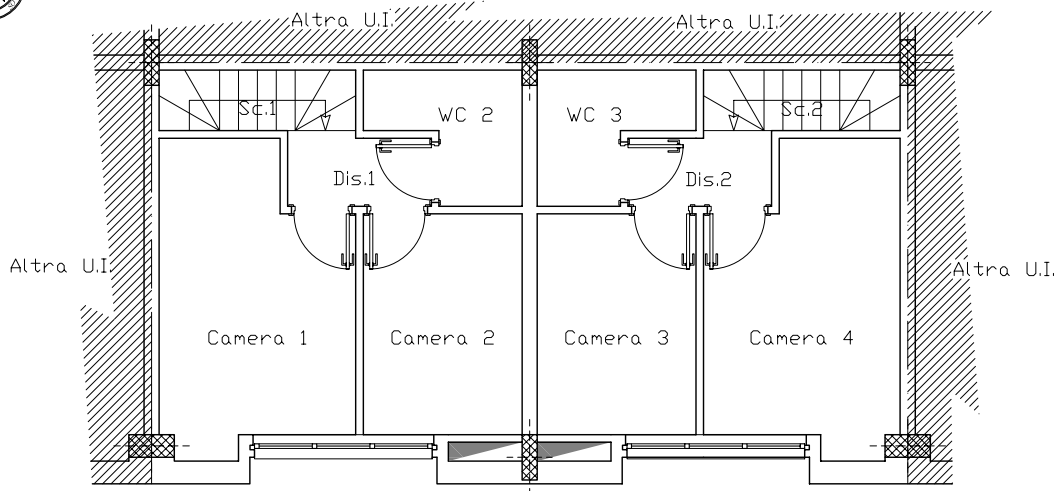

FOGLIO 25 - PARTICELLA 262 - SUB. 17
PIANTA PIANO PRIMO

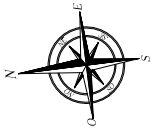

FOGLIO 25 - PARTICELLA 262 - SUB. 17
PIANTA PIANO RIALZATO

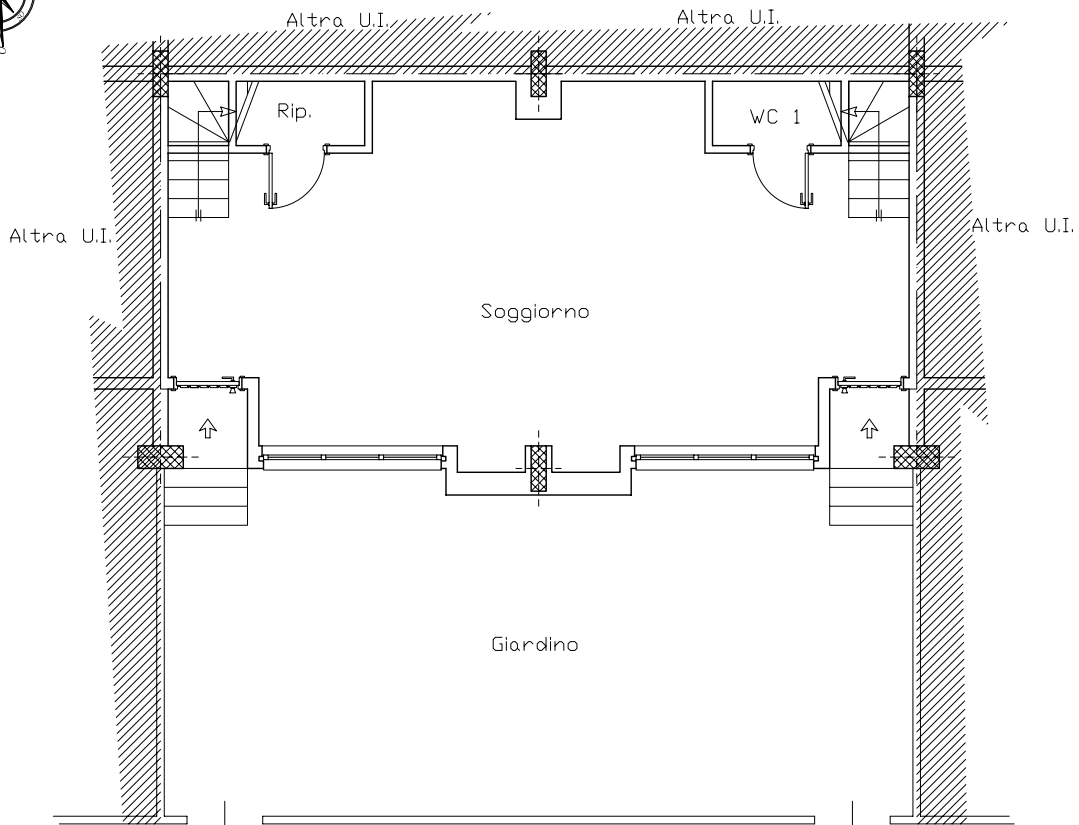
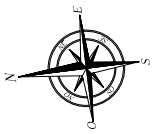

DOCUMENTO

SCALA

IL CTU

Sub. 31: Stato di fatto al 25/03/2013

1:100

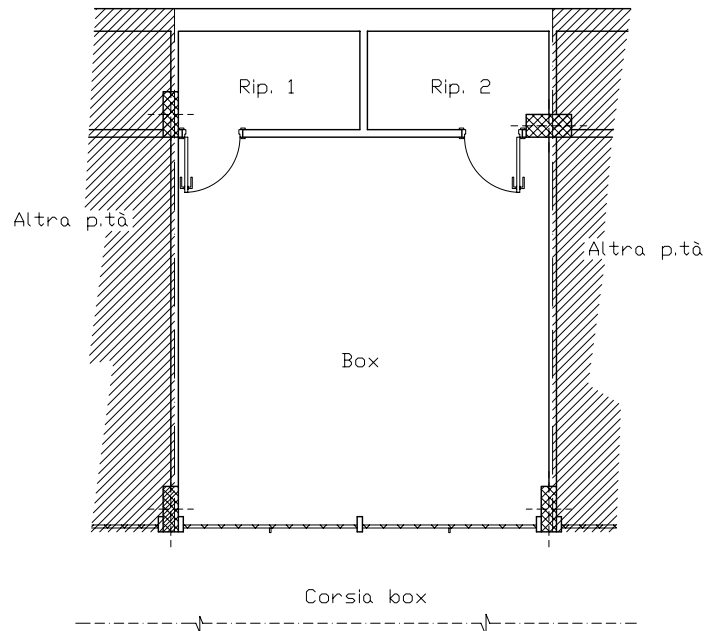
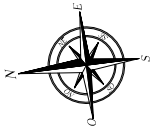
FOGLIO 25 - PARTICELLA 262 - SUB. 31
PIANTA PIANO INTERRATO

DATI METRICI DEL LOTTO

UNITA' IMMOBILIARE: Foglio 25, Particella 262, Sub. 17

Cod. Vano	Destinazione d'uso	Sup. Pavimento	Sup. Illuminante	S.P./S.I.	Altezza	Perimetro	Volume	S. Intonaco
1	Soggiorno	40.28	5.88	6.86	2.76	31.64	111.16	115.13
2	Rip.	1.45	0.00	===	2.76	5.10	3.99	13.98
3	WC 1	1.45	0.00	===	2.76	5.10	3.99	13.98
4	Sc1	2.08	0.00	===	2.75	6.80	5.72	20.57
5	Dis.1	1.80	0.00	===	2.75	5.80	4.95	10.66
6	Camera 1	9.49	1.70	5.58	2.75	13.74	26.10	44.03
7	Camera 2	6.13	1.16	5.28	2.75	10.04	16.86	31.03
8	WC 2	2.78	0.00	===	2.75	7.80	7.65	22.69
9	Sc2	2.08	0.00	===	2.75	6.80	5.72	20.57
10	Dis.2	1.80	0.00	===	2.75	5.80	4.95	10.66
11	Camera 3	6.13	1.16	5.28	2.75	10.04	16.86	31.03
12	Camera 4	9.49	1.70	5.58	2.75	13.74	26.10	44.03
13	WC 3	2.78	0.00	===	2.75	7.80	7.65	22.69
TOTALE INTERNO NETTO		87.74						
TOTALE INTERNO LORDO		100.45						

UNITA' IMMOBILIARE: Foglio 25, Particella 262, Sub. 17 - Superfici esterne

Cod. Vano	Destinazione d'uso	Sup. Pavimento	
1	Pianerottoli	2.08	
2	Giardino	44.68	
TOTALE ESTERNO ACCESSORIO		46.76	

UNITA' IMMOBILIARE: Foglio 25, Particella 262, Sub. 31

Cod. Vano	Destinazione d'uso	Sup. Pavimento	Sup. Illuminante	S.P./S.I.	Altezza	Perimetro	Volume	S. Intonaco
1	Box	24.56	0.00	===	2.45	19.84	60.17	69.54
2	Rip. 1	3.12	0.00	===	2.45	7.40	7.64	19.78
3	Rip. 2	3.06	0.00	===	2.45	7.40	7.50	19.72
TOTALE INTERNO NETTO		30.74						
TOTALE INTERNO LORDO		34.60						